

**TECHNICAL SPECIFICATIONS:**

- WEIGHT: 1134 lbs [514 kg]
- ELECTRICAL: 100/115/200/230 VAC @ 50/60 Hz
- AIR: 1 CFM @ 80 PSI [28 litre/min @ .55 MPA] (CLEAN, DRY AIR)
- PRODUCT PASS THROUGH: 6" [15,2 cm]
- PRODUCT WEIGHT CAPACITY: UP TO 15 lbs [6,8 kg] W/ SUPPORT CONVEYOR

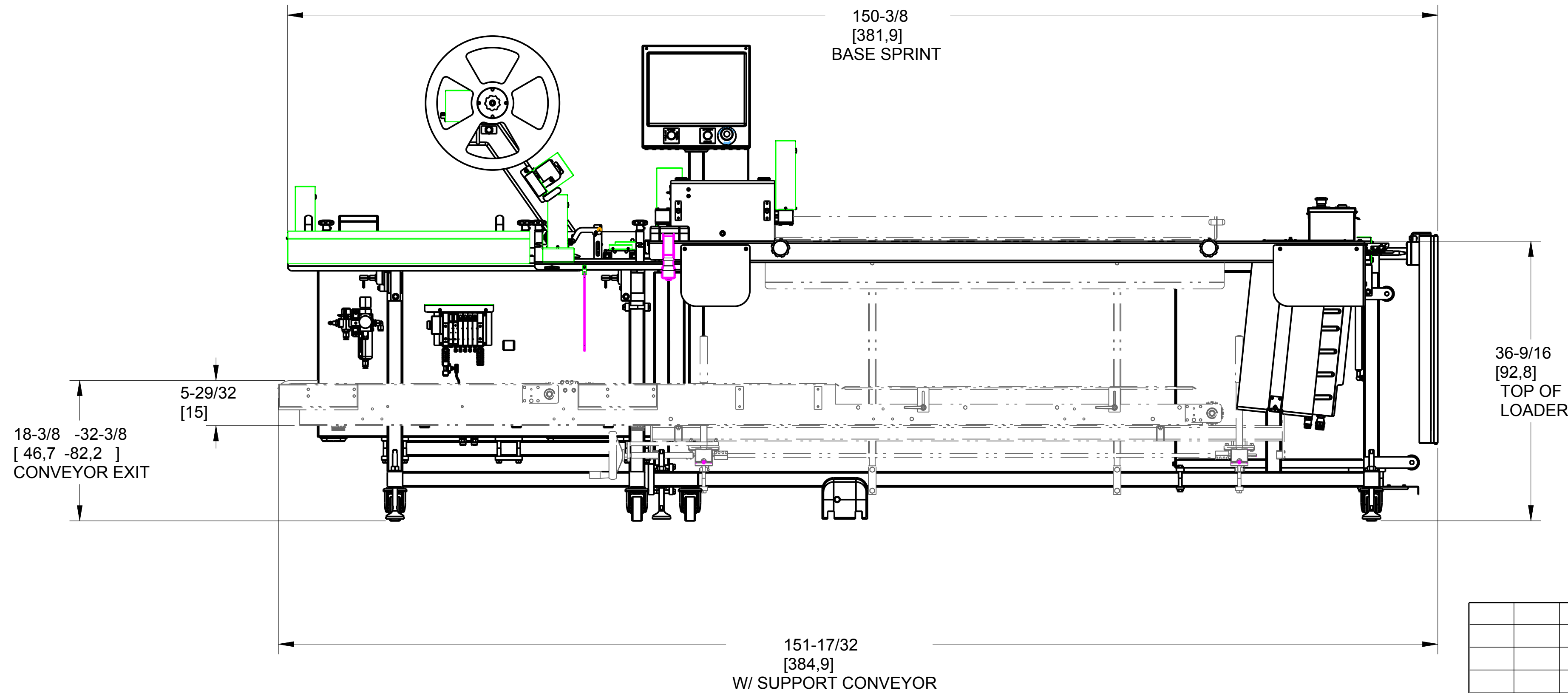
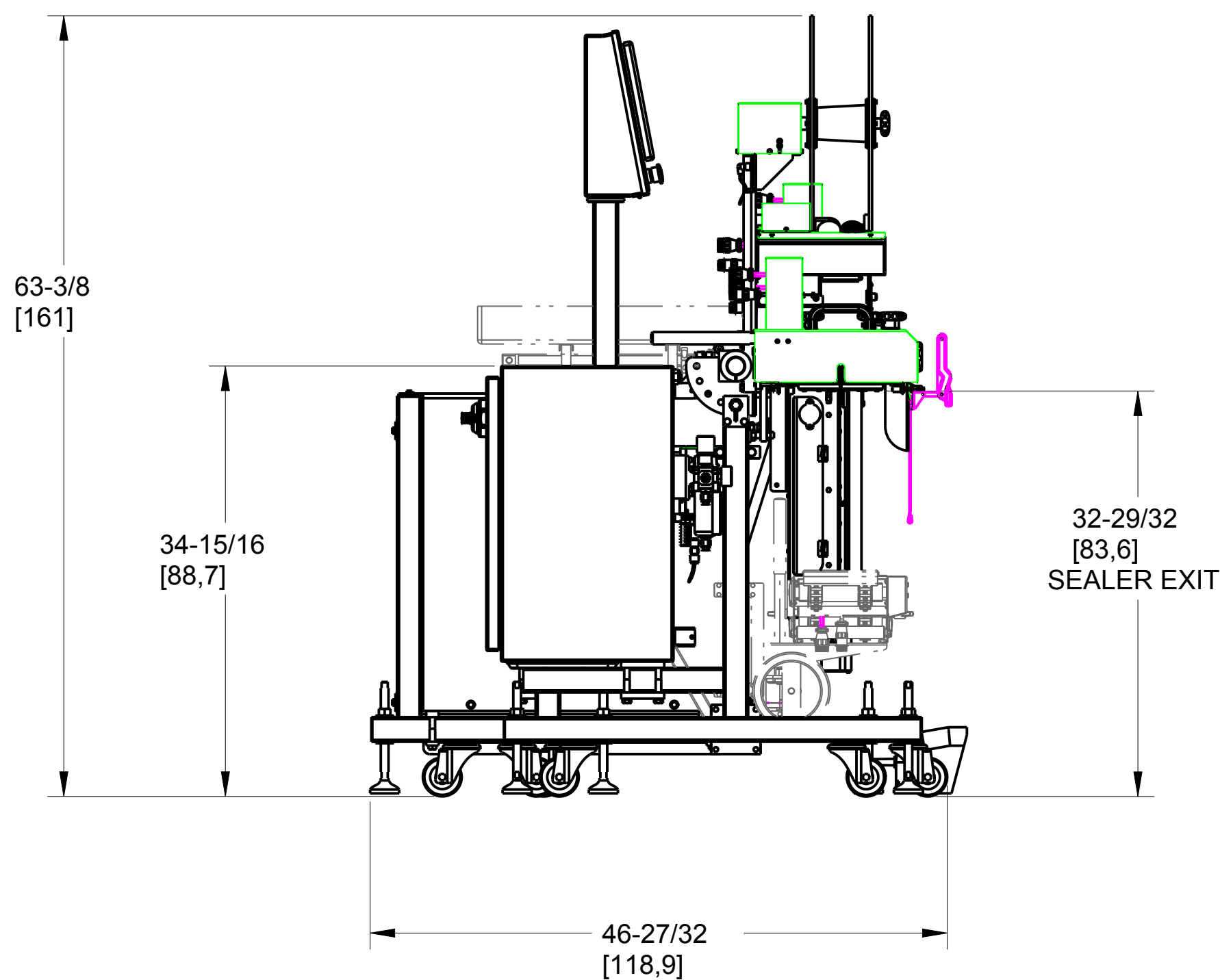
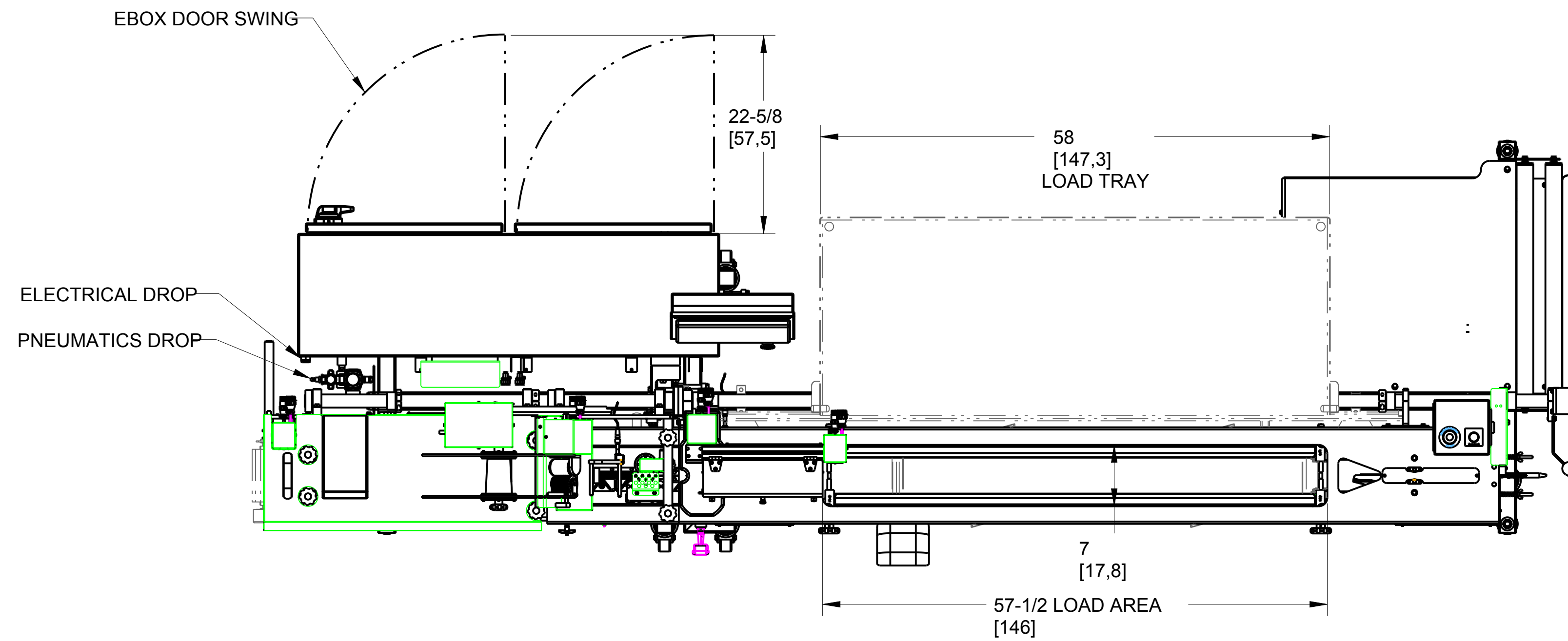

Fabricated & Documented to be RoHS Compliant

MATERIAL CODE	FINISH
PS110	<input type="checkbox"/> #3 BRUSH
PS113	<input type="checkbox"/> CS116-W
PS114	<input type="checkbox"/> CS116-P
CS115-W	<input type="checkbox"/> CS117-W
CS115-P	<input type="checkbox"/> CS117-P
	<input type="checkbox"/> 2B MILL
	<input type="checkbox"/> BLACK OXIDE
	<input type="checkbox"/> BLACK ANODIZE
	<input type="checkbox"/> CLEAR ANODIZE
	<input type="checkbox"/> OTHERS NOTED

REV	BY	DATE	ECN	CHK	DESCRIPTION

**Automated PACKAGING SYSTEMS**  
10175 PHILIPP PARKWAY - STREETSBORO, OH 44241

RELEASE LEVEL	TYPE EQUIPMENT
Concept	FAS SPRINT 2009
SCALE	DRAWN BY
3/32	LDC
DATE	09-09-09
TITLE	DRAWING NO.
FAS SPRINT 2009 W/ OPTIONS	FP210
	SHEET 1 OF 1
	REV
	A

INCH [CM]